

! INFO !

- (DE) Die Batterie des Zugfahrzeugs bzw. gezogenen Fahrzeugs nicht direkt über die Steckdose aufladen.
- (FR) Ne pas charger les batteries du véhicule tracteur et/ou tracté directement sur la prise de courant.
- (NL) De accu van het trekkend voertuig c.q. getrokken voertuig niet rechtstreeks via de contactdoos opladen.
- (GB) Do not charge the battery of the towing vehicle and/or towed vehicle directly via the socket.
- (ES) No recargue la batería del vehículo remolque y/o del remolcado directamente mediante el enchufe.
- (IT) Non caricare la batteria del veicolo trainante o di quello trainato direttamente dalla presa.
- (SE) Ladda inte batteriet i det bogserande fordonet och/eller det bogserade fordonet direkt via kontakten.
- (CZ) Nenabíjajte baterii tažného ani taženého vozidla přes zásuvku.
- (DK) Oplad ikke bugseringskøretøjet og/eller det bugserede køretøjs batteri direkte v.h.a. stikdåsen.
- (FI) Älä lataa hinaavan ajoneuvon ja/tai hinattavan ajoneuvon akkuja suoraan pistorasian kautta.
- (GR) Μη φορτίζετε την μπαταρία του ρυμουλκούμενου οχήματος και/ή ρυμουλκημένου οχήματος απευθείας μέσω του ρευματοδότη.
- (NO) Batteriet til kjøretøyet som trekker eller blir trukket skal ikke lades direkte via koblingsboksen.
- (PL) Nie ładować akumulatora pojazdu holującego/holowanego bezpośrednio przez gniazdo.

- (DE) Gebrauchsanleitung
(FR) Mode d'emploi
(NL) Gebruikershandleiding
(GB) User guide
(ES) Guía del usuario
(IT) Manuale di istruzioni
(SE) Bruksanvisning
(CZ) Uživatelská příručka
(DK) Brugervejledning
(FI) Käyttöohjeet
(GR) Οδηγός χρήστη
(NO) Brukerveiledning
(PL) Instrukcja obsługi

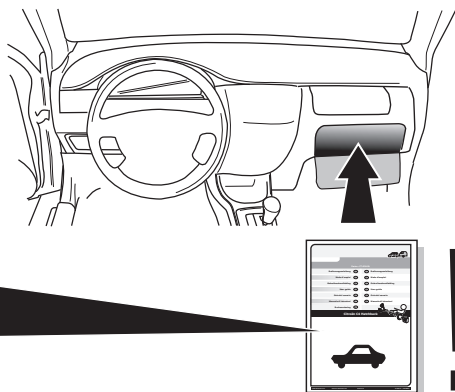

SPARE PARTS

www.ecs-electronics.com

ECS

ELECTRONICS



Partnr.: IS-002-DL

Gebrauchsanleitung (DE)

(CZ) Uživatelská příručka

Mode d'emploi (FR)

(DK) Brugervejledning

Gebruikershandleiding (NL)

(FI) Käyttöohjeet

User guide (GB)

(GR) Οδηγός χρήστη

Guía del usuario (ES)

(NO) Brukerveiledning

Manuale di istruzioni (IT)

(PL) Instrukcja obsługi

Bruksanvisning (SE)

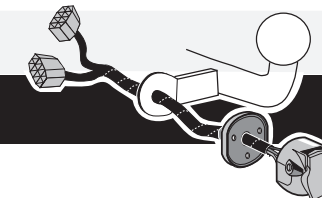

Isuzu D-max

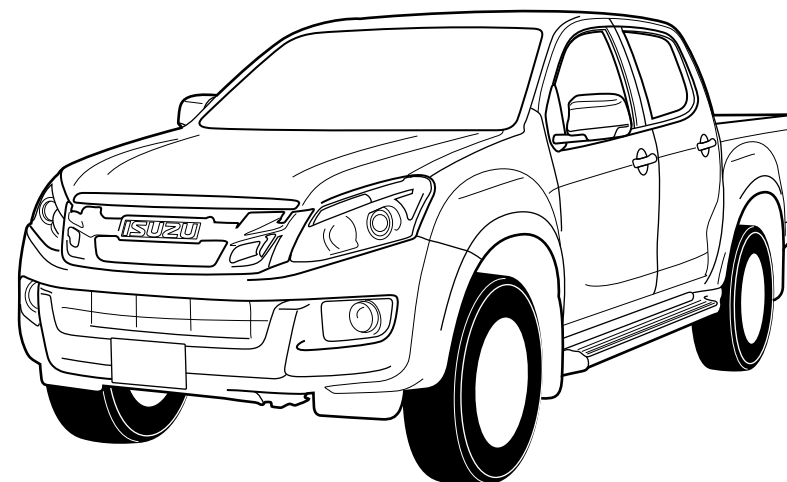

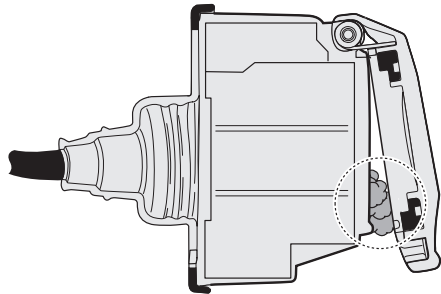

INFO : Storage

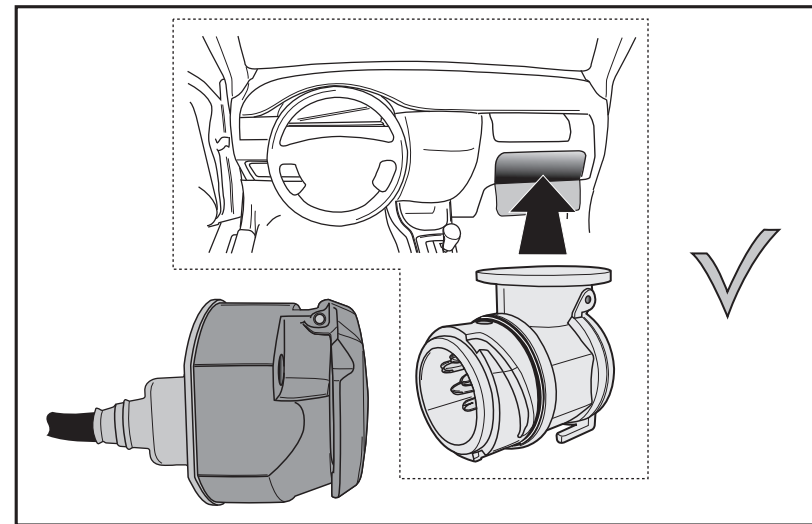
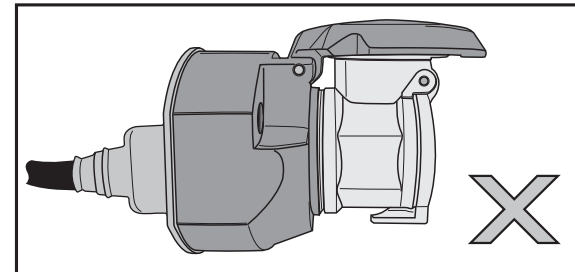
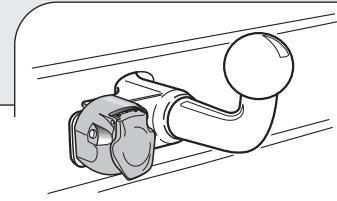
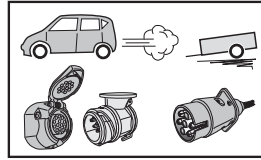

INFO : Ring.

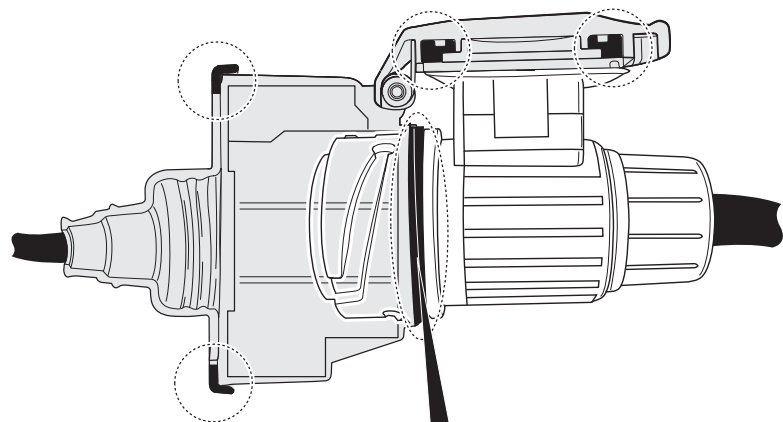
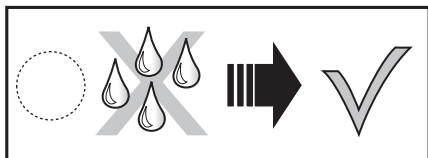
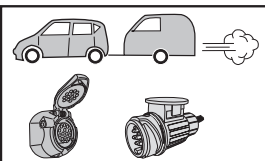

INFO

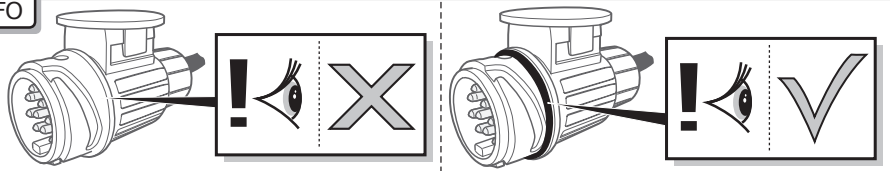



- DE** Die Kontrolleuchte blinkt, wenn beim angeschlossenen Anhänger, die Blinker (3x21W) oder Warnblinkanlage (6x21W) eingeschaltet sind.
- FR** Le deuxième témoin de contrôle clignote lorsque les feux de détresses (6x21W) et les clignotants (3x21W) du véhicule sont allumés alors que le caravane/remorque est accouplée au véhicule.
- NL** Het controle-lampje knippert wanneer bij aangesloten aanhanger de knipperlichten (3x21W) of waarschuwingslichten (6x21W) ingeschakeld zijn.
- GB** By switching on flashers with the trailer connected (3x21W) or the warning lights (6x21W), the 2nd direction indicator light will flash.
- ES** El piloto de control parpadea si, estando el remolque acoplado, las luces de destellos (3x21W) o de emergencia (6x21W) están encendidas.
- IT** La lampada di controllo lampeggia se, con il rimorchio agganciato, sono in funzione gli indicatori di direzione (3 x 21W) o le luci di pericolo (6 x 21W).
- SE** Kontrolllampan blinkar om blinkljusen (3x21W) eller varningsljusen (6x21W) är inkopplade hos den påkopplade släpvagnen.
- CZ** Zapnutím blikačů za připojeného návěsu (3x12W) nebo výstražných světel (6x12W) bude blikat druhé směrové světlo.
- DK** Hvis blinklysene tændes med anhængerens forbundet (3 x 21 W) eller advarselysene (6 x 21 W), blinker den anden retningsindikator.
- FI** Merkkivalo (toinen suuntavilkku) vilkkuu, mikäli autoon yhdistetyn perävaunun suuntavilkut (3x21W) tai varoitusvilkkuvalot (6x21W) ovat kytkettyjä päälle.
- GR** Ανάβοντας τα τόξα πορείας με το ρυμουλκό συνδεδεμένο (3x21W) ή τα προειδοποιητικά φώτα (6x21W), το 2ο φλας θα εκπέμψει λάμψη.
- NO** Kontrolllampen blinker når blinklysene (3x21W) eller varsellampene (6x21W) står på hos den tilkoblede tilhengeren.
- PL** Poprzez włączenie przerywaczy kierunkowskazów z podłączoną przyczepą (3x21W) lub świateł ostrzegawczych (6x21W) drugi wskaźnik kierunku będzie migać.

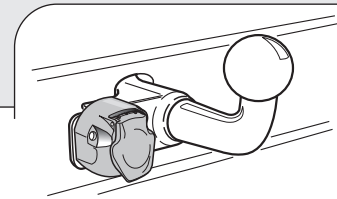

INFO : Adapt.

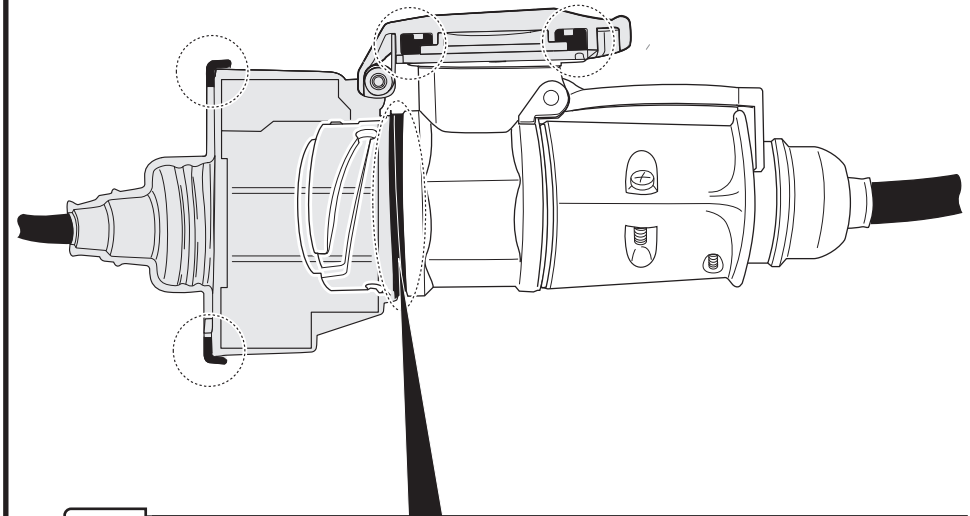
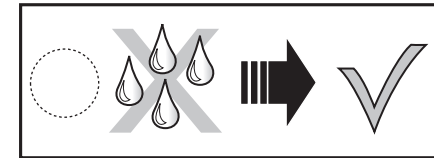
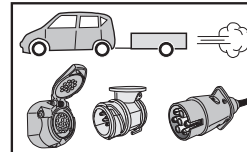

INFO

